

batch tankLINK

Temp., pH, EC and Level Sensors

Contents

Specifications	01	Technical Information	24-25
Overview	02	Warranty	26
Warnings and Notices	03-04		
Installation Instructions	04-06		
Device Registration	07-08		
Device Connections	09-10		
Accessories	11-12		
LCD Menu Operations	13-23		



Specifications

Input Power	24VDC, ~2W (5W w/LCD)
Max Cable Distance	1000ft
Interface	LCD w/3 Buttons + HUB Connection Port
Temperature Range	50-122°F (10-50°C)
Temperature Accuracy	±2°C, 0.1° resolution
pH Range	0-14pH
pH Accuracy	0.03pH, 0.01pH resolution
Conductivity Range	0-7,000 uS (0-3500ppm), 0-80,000 uS (high salinity/saltwater model)
Conductivity Accuracy	< 2000uS ±20uS, >2000uS ±50uS; 2uS resolution
Dimensions	4.625"W x 3.313"H x 1.313"D (117mm x 84mm x 33mm)

 **KEEP THESE INSTRUCTIONS**

Overview

The batch tankLINK ensures accurate tank monitoring by seamlessly integrating with your Growlink system. Equipped with sensors inputs for EC, pH, temperature, and tank levels, it automates refills and logs data for consistent oversight. Simplify tank management with reliable, automated tracking and alerts.

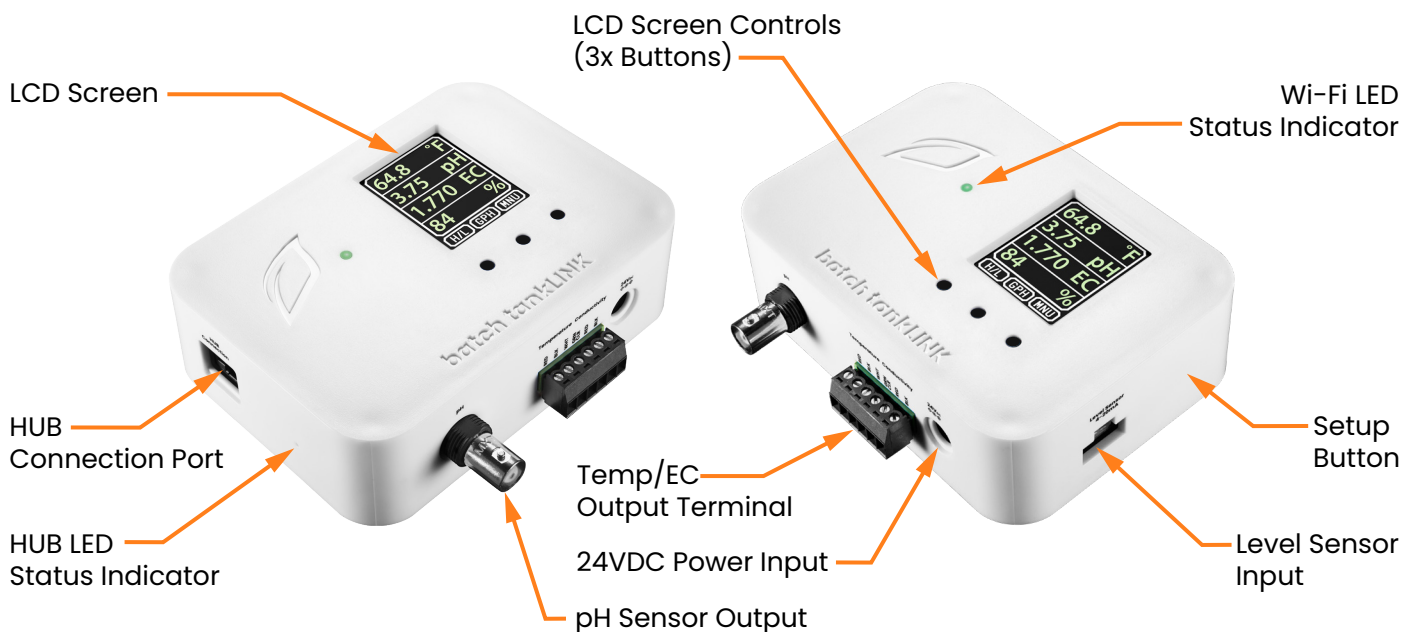

External Features:

LCD Screen: LCD panel for data and settings

HUB Connection Port: RJ-45 connection port

HUB LED Status Indicator: Indicates device power and HUB communication status.

LCD Screen Controls: LCD screen navigation control buttons (3x)

Temp/EC Output Terminal: Sends temperature and EC signal output.

Power Input: Input for 24VDC from included 24VDC power adapter.

pH Sensor Output: Sends pH signal to connected device.

Wi-Fi LED Status Indicator: Indicates Wi-Fi connection status.

Setup Button: Initiates setup mode and readdresses the batch tankLINK module.

Level Sensor Input: Connects to external level sensor device.

Warnings and Notices

This is a precision electronic instrument that requires careful handling and maintenance to ensure reliability. Failure to read, understand, and comply with warnings and installation requirements may result in property damage, personal injury, or death.

WARNING

READ & UNDERSTAND THE ENTIRE MANUAL BEFORE INSTALLATION OR OPERATION.

Danger: Electrocution Hazard

Disconnect power before performing maintenance or service on the system or its components to prevent equipment damage or electrical shock. Ensure proper grounding at the marked chassis ground terminal for continued protection against electric shock. All electrical equipment and wiring must be installed in compliance with national and local electrical codes. This product is for indoor use only in dry locations (0–75% RH, non-condensing). Use caution when servicing plumbing and drain the system away from electrical components and connections. Connect the system and components to GFCI fault-protected energy sources to reduce the risk of electric shock. Replace serviceable parts only with manufacturer-recommended components.

IMPORTANT SAFETY INFORMATION

This Product Is Not Intended for Life Safety Applications

Do not install in hazardous locations. Do not rely on this equipment as the sole control mechanism for life safety applications.

Installation Requirements

Follow all applicable plumbing and electrical codes when installing this product. This manual is intended for individuals with adequate electrical and mechanical experience who comply with federal, state, and local laws governing the installation, service, and repair of electrical, HVAC, and related equipment. Incorrect installation, service, or repair may result in personal injury and/or property damage. The manufacturer and seller assume no liability for misinterpretation or improper use of the information provided.

Indoor Use Only

This product is designed for indoor mounting only and must be protected from weather and direct sunlight.

Prevent Overheating

Maintain adequate airflow around the system to prevent overheating of system components.

Network Security

This product is a network-connected device and must be installed in a location inaccessible to unauthorized individuals. Failure to do so may result in unauthorized tampering with the device, its configuration, or network connectivity, potentially disrupting network operation or system performance.

Power Supply Warning

Only use the intended or included power supply. Do not exceed the maximum ratings specified on the product's serial label or in this manual. Any power supply exceeding specified energy levels must be current-limited or fused to prevent overcurrent damage.

Dielectric Grease Recommendation

In humid environments, apply dielectric grease to RJ-45 HUB connections to prevent moisture-related corrosion. Recommended products include Loctite LB 8423 Grease, DuPont Molykote 4/5, CRC 05105 Di-Electric Grease, Super Lube 91016 Silicone Dielectric Grease, and other silicone or lithium-based insulating greases. Apply a small amount of grease to RJ-45 plug contacts before inserting them into the HUB connection port.

California Proposition 65 Warning

This product may contain chemicals known to the State of California to cause cancer, birth defects, or other reproductive harm. Wear skin and eye protection when handling hazardous chemicals.

Installation Instructions

Before Installation

For optimal protection, install the unit with the power connection facing downward to minimize the risk of water entering the enclosure. This product is designed for indoor installation only, as the enclosures are not waterproof.

Before connecting or disconnecting any cables, disconnect power from all devices to prevent potential damage to components.

Mounting the Enclosure

For optimal performance, mount equipment outside of the growing environment to allow better service access and reduced exposure to humidity. If a batch tankLINK is to be installed in a humid environment, use a sealed enclosure.

Follow these tips for best results:

- Install the batch tankLINK in a dry location away from drips or condensation.
- Install the batch tankLINK in the designated mounting area, ensuring there is sufficient space for all necessary connections.
- Ensure the batch tankLINK is accessible for service.
- Use a weatherproof enclosure for high humidity conditions (<70% continuous).
- To prevent dust or contamination during installation, cover jacks with masking tape.

Wall Mounting

See Instructions and Diagram Below

Parts: LINKS Device, LINK Hardware Kit (Mounting Bracket, Screws, Anchors, Mini-Screwdriver).

Tools Needed (if necessary): Level, Marking Tool, Drill

1. Attach the **Device Mount Bracket (Top)** with the provided screws. Ensure the counter-sunk holes face forward. Do not over-tighten.
2. Position the **Wall Mount Bracket (Bottom)** on the wall. Mark the hole locations and install anchors or pre-drill holes if necessary.
3. Slide the **Device** into place, aligning the **(Top) Device Bracket** with the **(Bottom) Wall Mount Bracket**.

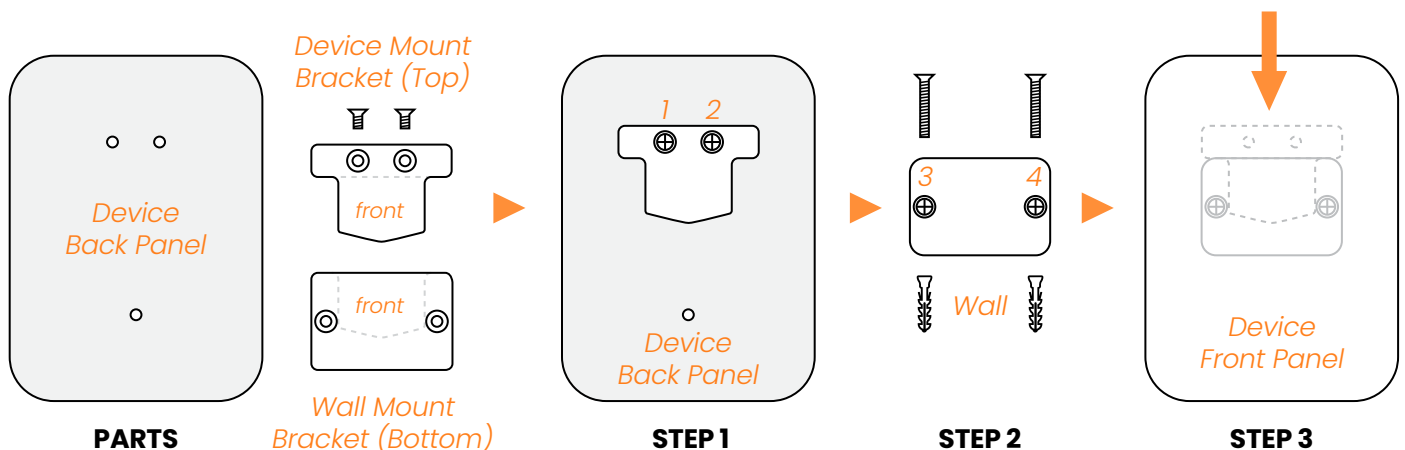

DIN rail Mounting

These sturdy DIN rail mounting clips come in handy where standard DIN rail is used for mounting devices. The flat mounting surface and a variety of mounting holes make these clips versatile for mounting LINK devices.

See Instructions and Diagram Below

Parts: LINKS Device, DIN rail Clip Kit, (Sold Separately)

Tools Needed (if necessary): Phillips Screwdriver

1. Position at an Angle

Hold the device at a slight angle with the top part of the DIN rail clip hooking onto the top edge of the rail first. Ensure proper alignment to avoid unnecessary force on the clip.

2. Snap into Place

Gently rotate the bottom of the device toward the rail while applying light pressure. The spring-loaded or flexible lower clip should compress slightly and then snap into place once fully engaged.

3. Verify Secure Fit

Check that the device is firmly seated on the rail by giving it a gentle tug. It should not shift or wobble excessively.

4. Careful Removal: Lift and Pivot

To remove, compress the spring of the mount by gently pressing the device upwards. Once spring is compressed, tilt the top of the device outward at an angle. Then, once top is free, guide device downwards to release from DIN rail completely. Do not force or twist to prevent breaking plastic parts,

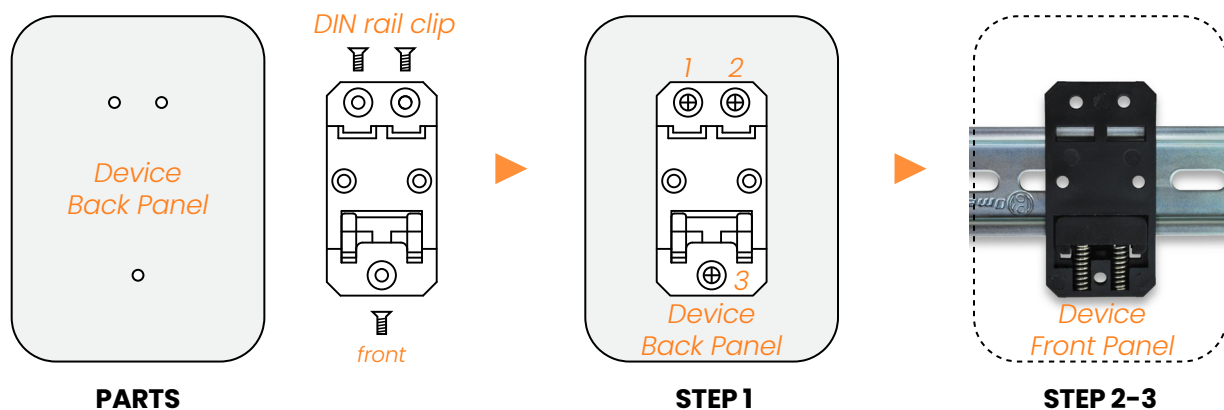

Device Registration

All LINKS devices require an internet connection and registration through the Growlink App.

Note: Some LINKS devices can be standalone or require additional modules.

HUB Connection Method

The batch tankLINK does not draw power from the HUB. It requires a 120VAC power source connected to a 15A branch-protected circuit. An internal power supply converts this input to 24VDC to operate the batch tankLINK electronics.

Note: A HUB must be registered with the Growlink App before connecting any additional devices. After completing the HUB setup, each device must be connected and registered one at a time to ensure proper addressing and system integrity.

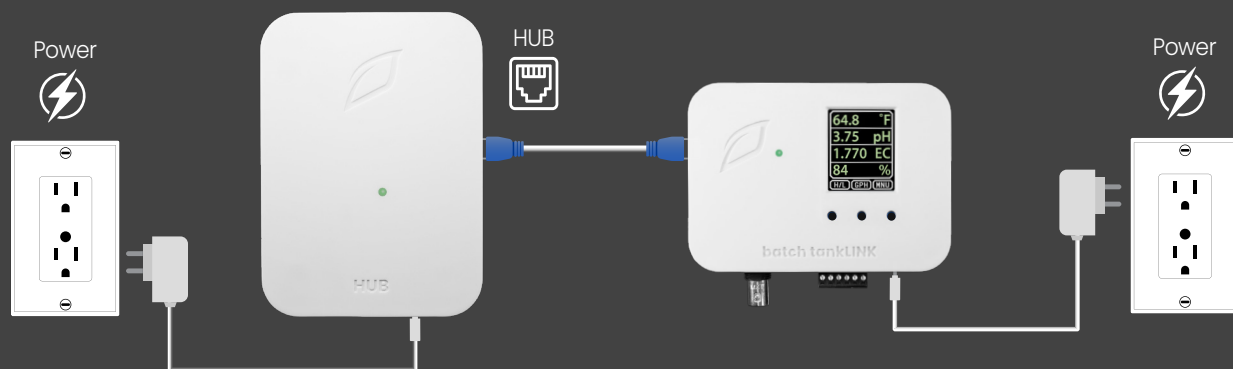

Wi-Fi Connection Method

The batch tankLINK requires a 120VAC power source from a 15A branch protected circuit. A built-in DC power supply operates the electronics in the batch tankLINK from the 120VAC input. During device registration, a strong signal is recommended, and a password-protected connection is required.



Connection to the Growlink App

The Growlink Mobile App provides remote access to your grow operation, allowing real-time monitoring, system adjustments, and automation of climate, lighting, and irrigation. The app features advanced analytics, push notifications for alerts, and an intuitive interface for efficient management.

The Growlink Mobile App enables remote control over your LINKS devices for:

- Firmware Updates
- Manual Device Operation
- Creating Automation Rules
- Viewing Data
- Sending Alerts
- Various Other Features

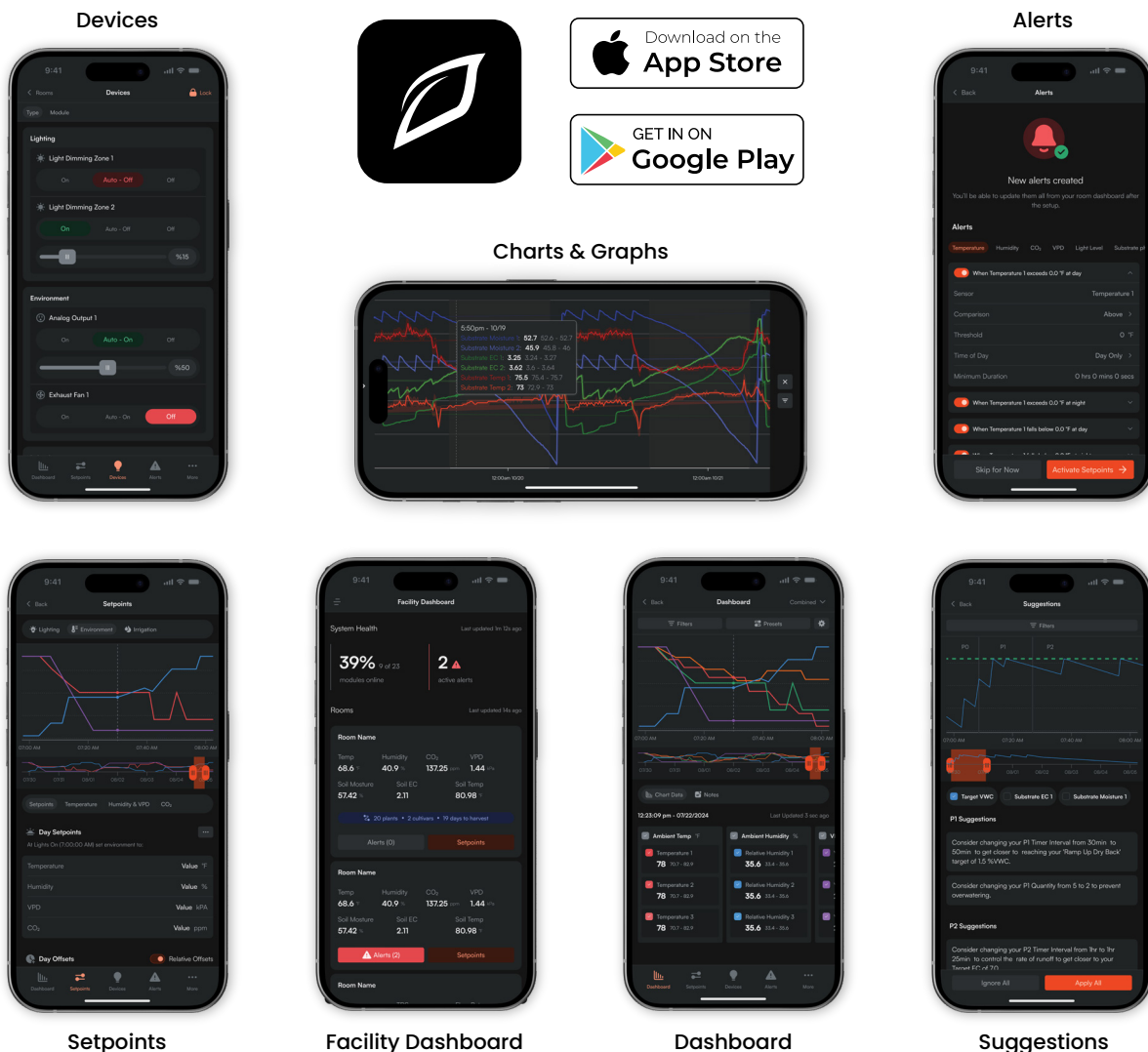

Device Connections

Begin by connecting the batch tankLINK to a standard 120VAC power source using the supplied power supply. Next, connect the batch tankLINK to your Growlink HUB using the designated communication port. This ensures proper system communication before devices are added. Once the batch tankLINK is powered and linked to the HUB, plug your devices—into the output ports. Make sure all connected devices are within the rated capacity.

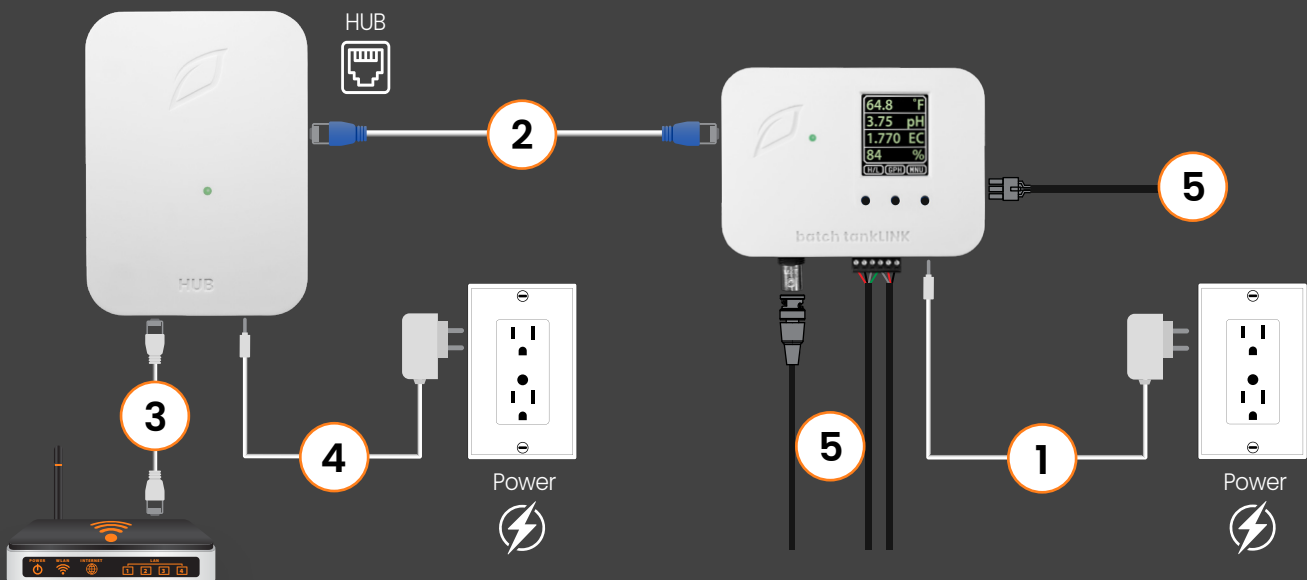

- 1. batch tankLINK Power Supply:** 120VAC power supply is required to operate the device.
- 2. Device Cable:** Connects the batch tankLINK to a HUB Connection Port.
- 3. HUB Ethernet Cable:** Connect the HUB to the local network (Optionally, utilize 2.4GHz Wi-Fi).
- 4. HUB Power Supply:** 24VDC/1 Amp power supply is required to operate the HUB.
- 5. batch tankLINK Outputs:** Plug in sensor devices.

All HUB connection cabling uses standard 8-conductor RJ-45 straight-through wiring with no cross-over. T568B pattern recommended.

Safety Note: Always power off the batch tankLINK before connecting or disconnecting devices. Ensure all connections are secure and dry before powering on.

Connecting Sensors

pH sensors are equipped with “BNC” style connectors which push on and then turn 1/4 rotation CW to lock them in place. **Temperature** and **Electrical Conductivity Sensors** have a screw terminal block; make the connections according to the label on the transmitter. The terminal block may be removed for service.

- Some Conductivity Sensors may not have a “clear” wire and may only have a red and black wire.
- Temperature Sensors with green wire connect to the “CLR” terminal.

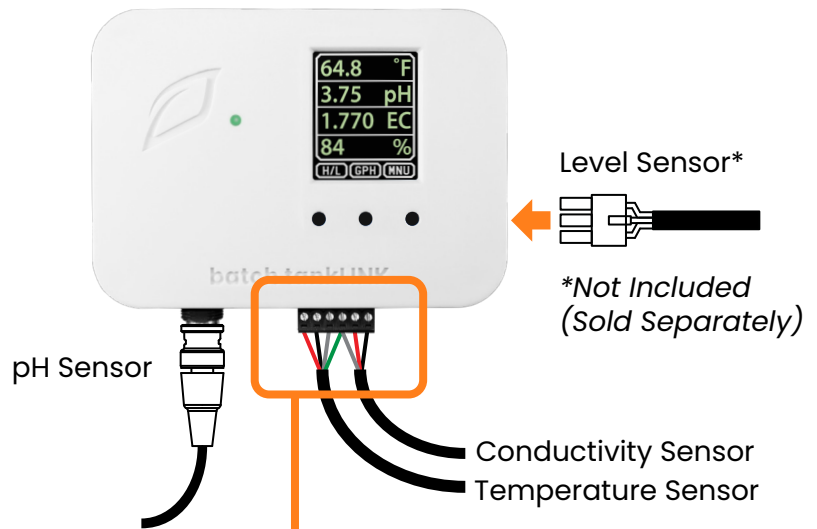

Temperature Sensor

Conductivity Sensor

Accessories

Sensor Pontoon*

Sensors can be floated directly in a water tank using a pontoon, which is designed to keep the sensors in consistent contact with the water as the level changes. The serpentine shape of the pontoon allows for easy installation through narrow tank openings.

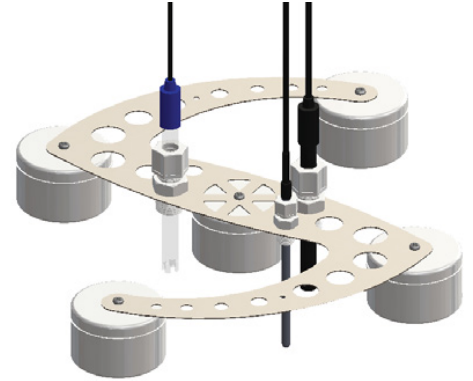

Sensor Manifolds*

Sensors may be installed "inline" with flow using 1" series sensor manifolds. Manifolds include removable compression fittings to seal the sensors, and o-ring seals on the manifolds for easy removal during calibration.

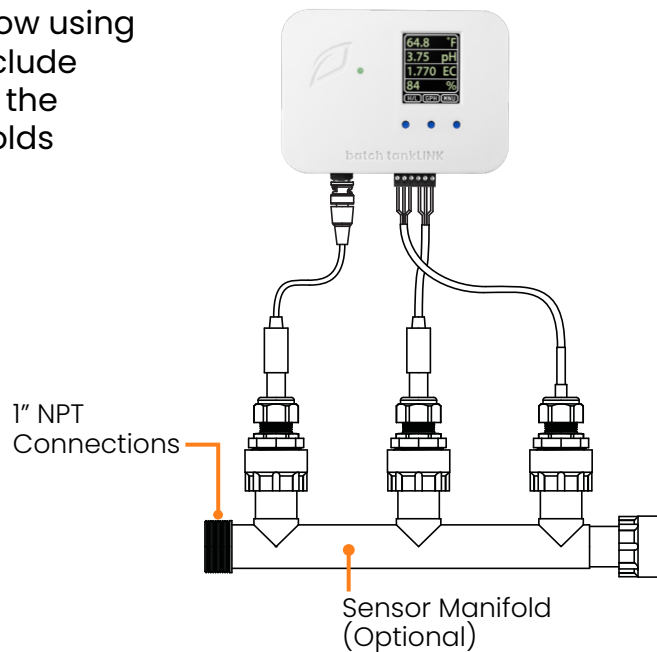
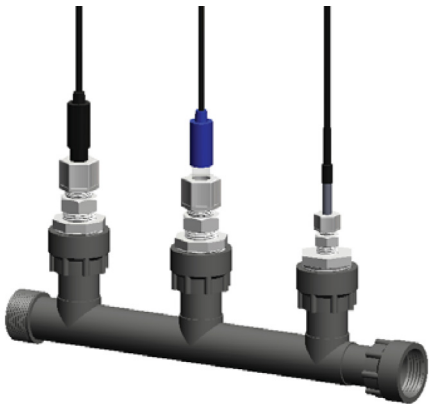

NOTE:

Recommended for flow rates up to 30 gpm, max pressure 60 psi. For flow rates above 20 gpm, ensure sensor tips are raised out of the flow path to prevent turbulence altering the sensor readings.

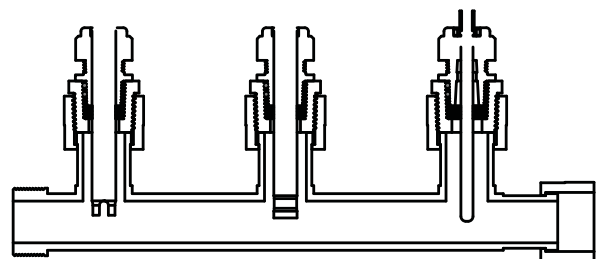

* Items shown on this page are optional accessories and are sold separately.

pH Sensor Preparation, Shipping and Storage

pH sensors are shipped in a plastic bottle containing a solution of pH 4 buffer and potassium chloride. The electrode should remain in the bottle until it is used.

If the electrode is used infrequently, the bottle and its solution should be saved and the electrode stored in it. If the solution in the soaker bottle is missing, fill the bottle with pH 4 buffer.

Take out electrode by loosening plastic top on bottle counterclockwise and pulling electrode out. Slide cap and O-ring off electrode and save.

pH must remain wet to avoid damage. Do not allow sensor tips to dry.

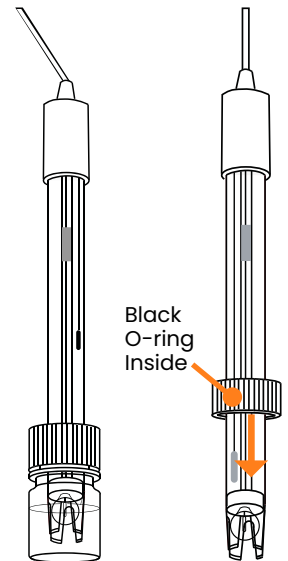

Air Bubble

During shipment, the air bubble in the electrode stem may shift into the bulb area. If you notice bubbles in the bulb, hold the electrode by the top cap and gently shake it downward to return the bubble to the stem.

Installation/Operation Angle

pH sensor must be installed in an above-horizontal position with the sensor tip facing downward to prevent the air bubble from entering the bulb area.

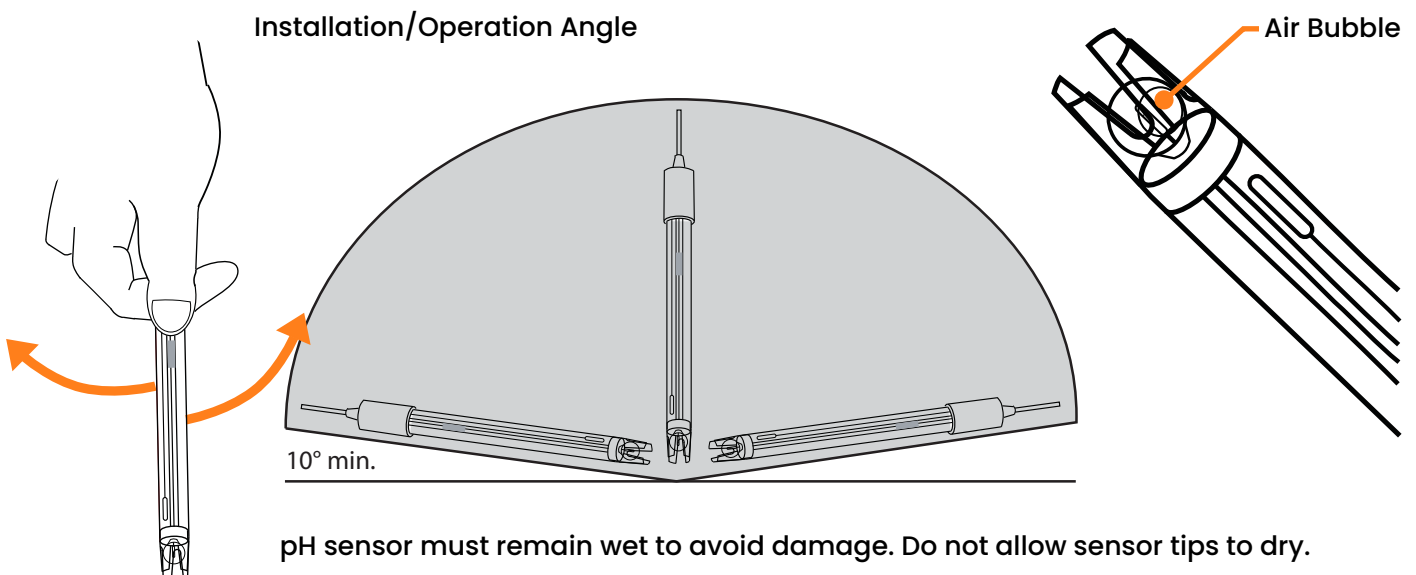

pH sensor must remain wet to avoid damage. Do not allow sensor tips to dry.

LCD Menu Operations

The main screen displays real-time sensor readings from all connected sensors. Each button is labeled along the bottom of the display, indicating its specific function based on the current screen or menu.



The batch tankLINK interface may be used for stand-alone monitoring applications or as part of a control.

Manufacturing Info



Manufacturer information such as serial number, date of manufacture, hardware and firmware versions can be read from the MFG INFO page.

1. Select **MFG INFO** from the **SETUP** menu.
2. Press **EXIT** to return.

1.

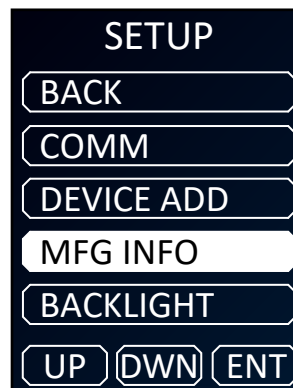

2.

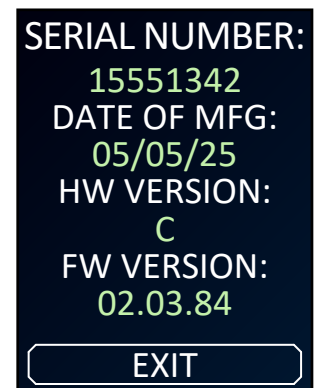

Main Menu

The main menu provides access to alarm settings, sensor calibration, and general configuration options such as time, date, and units.



Use the **UP** and **DWN** buttons to navigate through the menu options, and press the **ENT** button to enter a selection.

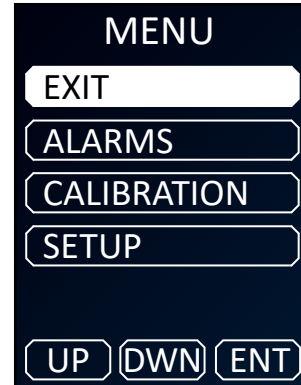

Setup Menu

The setup menu is where the time and date are set, the units are configured, logging interval is adjusted.

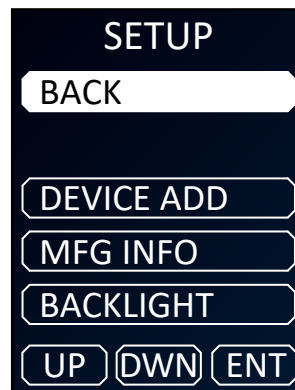
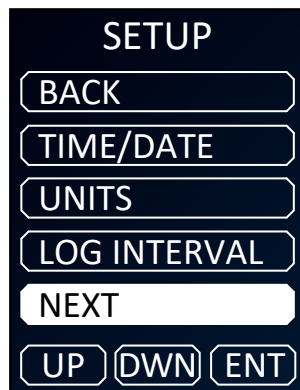

Time and Date

Sensors include a precision real-time clock with battery back-up for time-stamping the data log information with the time and date. The last calibration for each sensor is also time stamped.

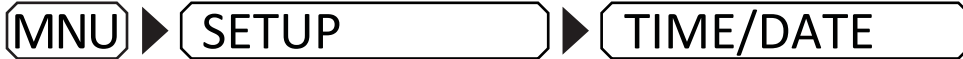

1. Select **TIME/DATE** from the setup menu.
2. Select **TIME** or **DATE** to adjust.
3. Use **NXT** to select the value to adjust. Use + to increment the value.
4. Use **EXT** to exit the menu.

1.

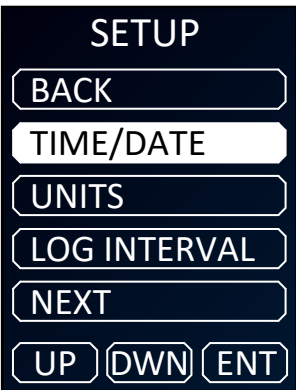

2.

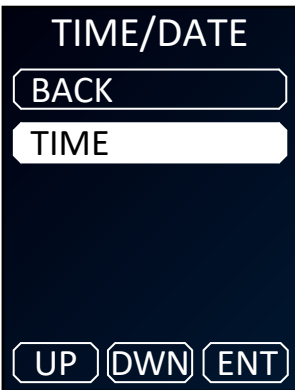

3.



4.



Units

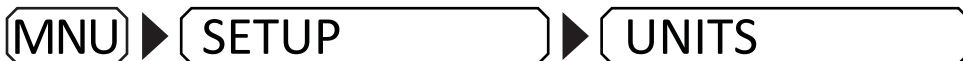

Temperature and Conductivity may be displayed in alternate units.

Select a sensor value to change the default display and working units.

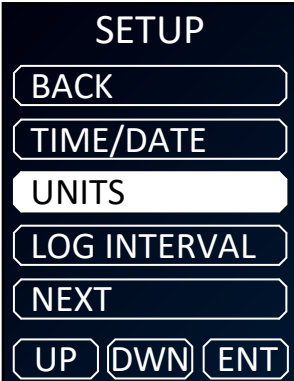

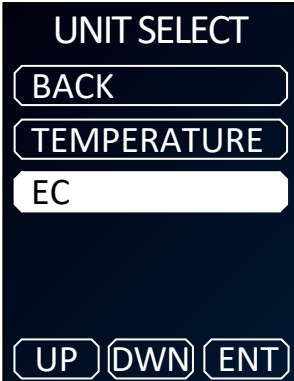

Configure Temperature Units

Temperature may be displayed in °F or °C.

Note: Check alarm settings when converting temperature units.

1. Select **TEMPERATURE** from the units menu.
2. Select the desired units then press **ENT**.

1.

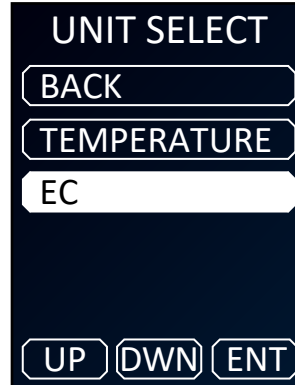

2.

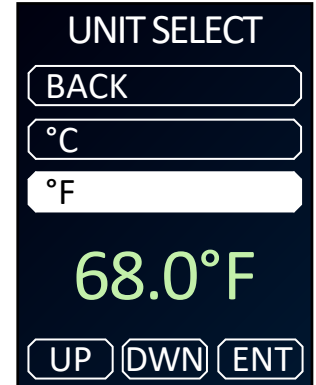

Configure Conductivity Units

Conductivity may be displayed in default units of EC or Total Dissolved Solids in parts per million (ppm.)

The TDS conversion factor used by this meter is 500.

1. Select **EC** from the units menu.
2. Select the desired units then press **ENT**.

1.

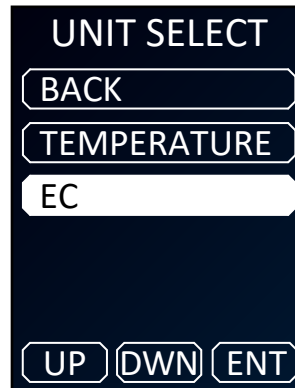

2.

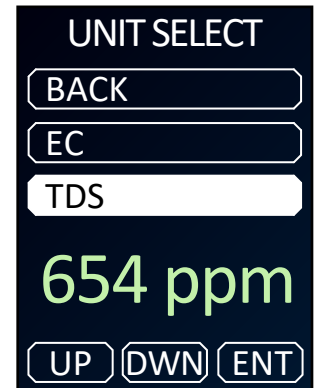

Display Back Light Timer



The display back light can be programmed to turn off after a specified time of inactivity from the last time a button was pressed.

The delay can be set from 1-255 minutes, or set to 0 to disable the back light timer and keep the display on continuously.

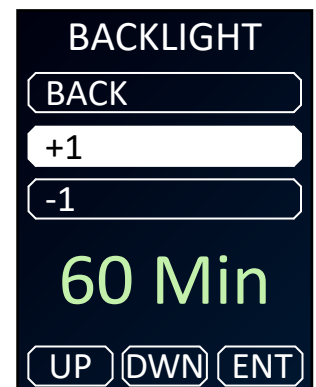
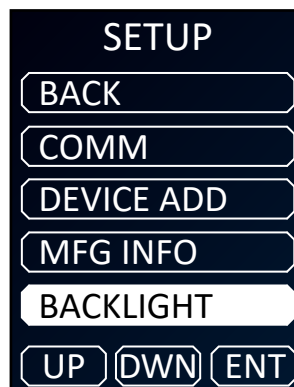

Device Address



Sensors are digitally addressable from 1-249 and will be assigned an address automatically or can be configured manually via the menu.

1. Select **DEVICE ADD** from the setup menu.
2. Adjust the value then select **BACK**.

1.



2.



Logging Interval

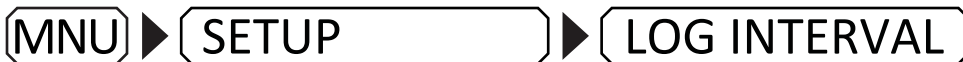

Adjust the interval for recording data points in the on-board memort. Acceptable values are from 1-65535 seconds.

21,600 data points can be stored for each sensor value. The most recent 120 data points are shown on the graphical history.

The entire data history may be downloaded from the sensor to a .csv file the LINKS software.

Note: 60 second intervals = 15 days of data storage.

1. Select **LOG INTERVAL** from the setup menu.
2. Adjust the value then select **BACK**.

1.

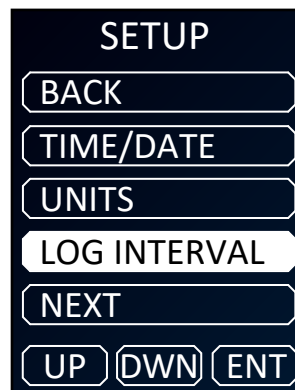

2.

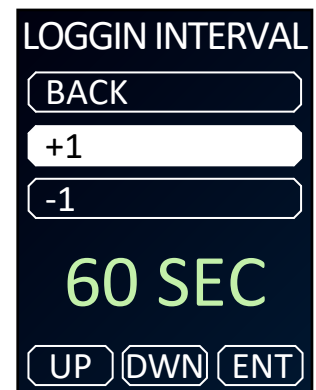

Alarms Menu

High and Low alarm set points may be configured for each sensor. The out-of-range value will be displayed in red to indicate the cause for the alarm.

Additionally, alarm limits are plotted on the graphs to indicate values are within the desired range.

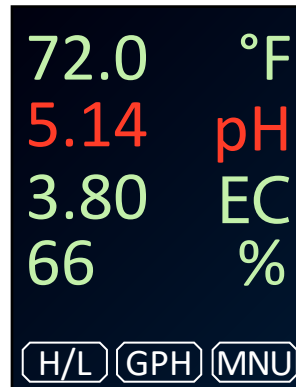

Alarms Configuration

1. Select **ALARMS** from the Main Menu.
2. Select a sensor to configure set points.
3. Select the setting to adjust.
4. Adjust to the desired value. Hold **UP** or **DWN** to jog the value.

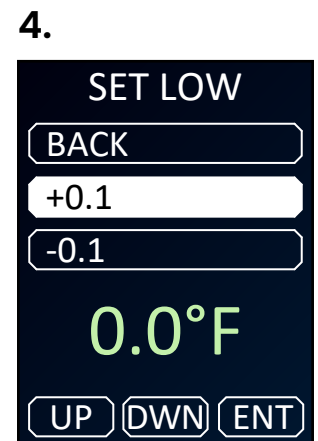
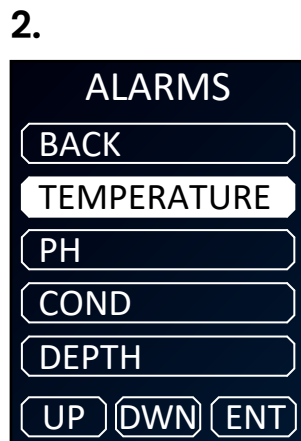
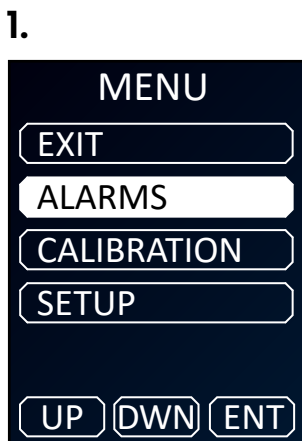

Graphing

The display can graph up to the most recent 120 data points from the sensor's internal memory. With the default logging interval of 60 seconds, the graph provides a 2-hour view of recent sensor data.

Sensor values are plotted in green. If temperature is overlaid, it appears in red. User-defined alarm levels are displayed in yellow.

Press the **RFH** button to refresh the data and update the graph.

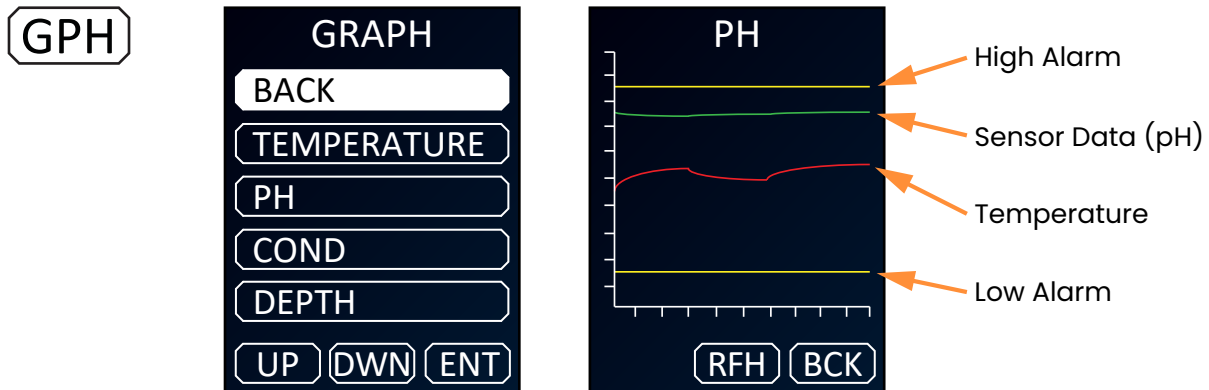

High/Low History

The device tracks and stores the minimum and maximum values until manually reset. To view the high and low readings since the last reset, press the **H/L** button.

To clear the history, press the **RST** button. This resets both the minimum and maximum values to the current readings. New highs and lows will be recorded automatically as they occur.



Calibration Menu

Calibration can be performed for each sensor with the LCD interface using the calibration wizard.

The date of the last calibration for each sensor is stored in memory and displayed at the start of each calibration wizard.

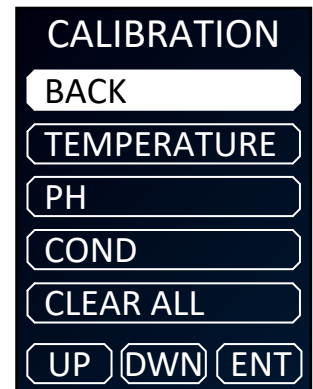
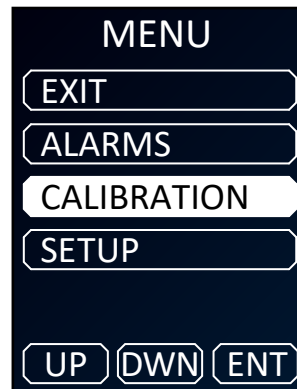

Temperature Calibration

1. Select **CALIBRATE** from Calibration menu.
2. Press **NEXT** to continue.
3. Adjust to the desired value. Hold **ENT** to jog the value by 10x.
4. Confirm the new reading or press **NO**.

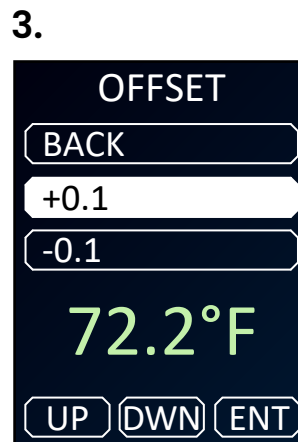
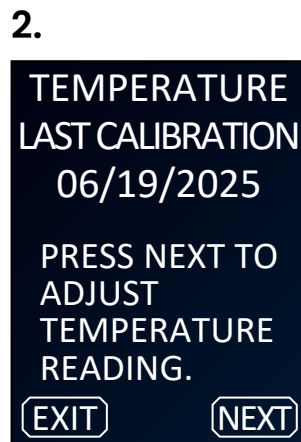
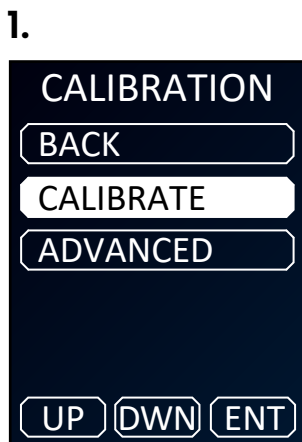



pH Calibration

pH calibration is a two-point process requiring both pH 7 and pH 4.01 calibration solutions. The temperature sensor must be inserted into the calibration solution at the same time as the pH sensor.

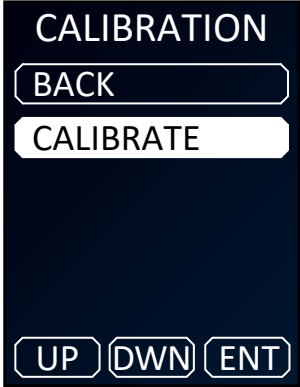

- 

Select **CALIBRATE** from Calibration Menu.
- 

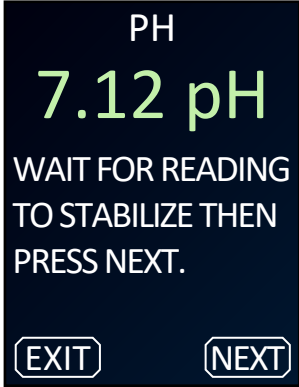
Follow the instructions then press **NEXT**.
- 

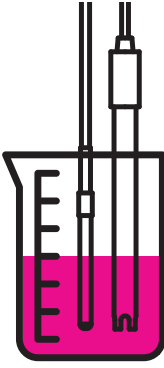
When the reading is stable, press **NEXT**.
- 

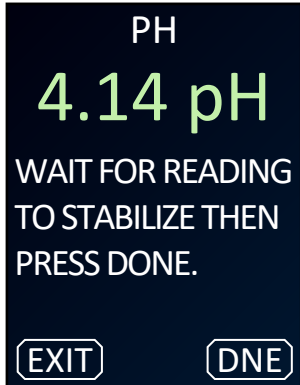

Clean the sensors with DI/RO and change calibration solution.
- 

When the reading is stable, press **DONE** to calibrate pH 4.01 and finish calibration.

Level Sensor Calibration

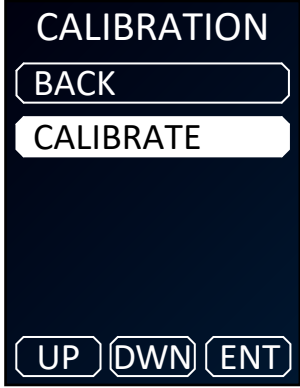

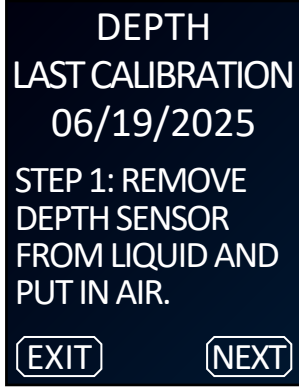

- 

Select **CALIBRATE** from the Calibration Menu.
- 

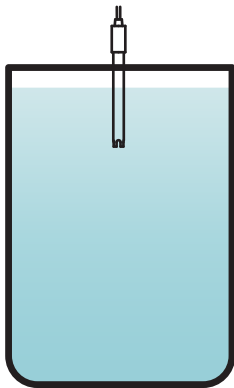
Have sensor in open air then press **NEXT** to continue.
- 

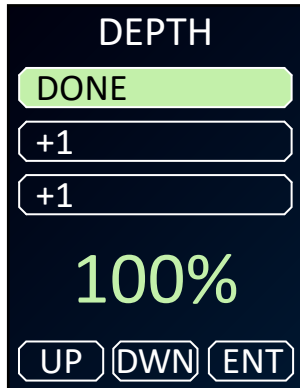
Allow reading to stabilize then press **NEXT**.
- 

Place sensor in full tank, allow reading to stabilize then press **NEXT**.
- 

Set the value you want to represent a full reading.
- 

Confirm the calibration.

Conductivity Calibration

Conductivity calibration is a single point process requiring 1413 uS calibration solution. The temperature probe must be inserted into the calibration solution at the same time as the conductivity probe.



1.

Select **CALIBRATE** from conductivity calibration menu.

2.

Follow the instructions then press **NEXT** to continue.

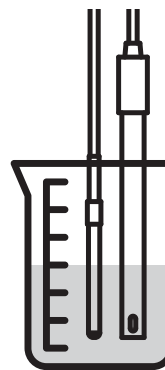

3.

When the reading is stable, press **DONE** to complete the calibration.

Clear Calibration



Clear Calibration

1. Select **CLEAR ALL** from the Calibration Menu.
2. Press **YES** to restore factory calibration. calibration can be restored to factory defaults by selecting **CLEAR ALL**.

1.

2.

Technical Information

Maintenance & Service

Exterior Cleaning

Wipe the exterior with a damp cloth and mild dish detergent, then dry thoroughly. **Disconnect power before cleaning** to prevent equipment damage.

Sensor Cleaning

Sensors require periodic cleaning, reconditioning, and calibration to maintain reliable performance. Refer to the calibration section for instructions on performing calibration after cleaning.

Coating of the pH bulb can lead to inaccurate readings. Similarly, coatings or blockages on the EC sensor may result in incorrect measurements. The appropriate cleaning method depends on the type of contamination present.

- Soft coatings can often be removed by vigorous stirring in clean water or by using a squirt bottle.
- Organic residues or hard coatings may require chemical removal.
- Do not use brushes or abrasives on pH or EC probes, as this may damage the sensing surfaces.

DO NOT use brushes or abrasive materials on pH or EC probes, as this can permanently damage the sensor surfaces.

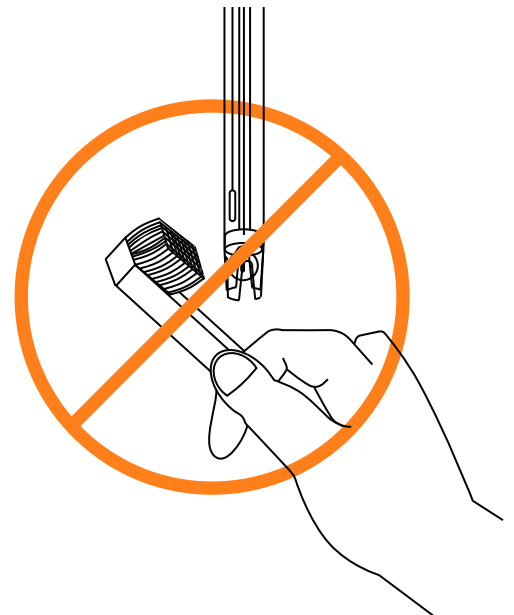

Troubleshooting

Wi-Fi LED Status Indicators



Standard Startup Flow

- Firmware Startup
Solid white
- Wi-Fi Connecting
Slow flashing green
- Network Waiting on IP Address
Fast flashing green
- Network Connected, Connecting to Cloud
Fast flashing cyan
- Loading Configuration and Detecting Probes
Fast breathing green
- Connected to Cloud and Running
Slow breathing green

Other Modes

- Wi-Fi Configuration Mode
Slow flashing blue
- Safe Mode
Slow breathing magenta
- Safe Mode Requested
Fast flashing magenta
- Firmware Updating
Slow flashing magenta
- Module Mode
Breathing cyan
- Wi-Fi Error
Flashing yellow

Support

If your device requires troubleshooting beyond what is outlined in this manual, please contact our customer support team at 800.432.0160 or at support@growlink.com for assistance with any hardware issues.

You can also visit our knowledge base for additional support and resources.

<https://knowledgebase.growlink.ag>

Storage

Store equipment in a **clean, dry environment** with an ambient temperature between 50-122°F (10-50°C).

Disposal

This industrial control equipment may contain traces of lead, metals, or other environmental contaminants. **Do not discard as municipal waste.** Dispose of the equipment through proper recycling or hazardous waste collection channels. **Wash hands after handling internal components or PCBs.**

Warranty

Growlink Limited Warranty

Growlink warrants that all its manufactured products are, to the best of its knowledge, free from defects in materials and workmanship. This product is warranted for one (1) year from the date of purchase. This warranty is extended to the original purchaser from the date of receipt.

This warranty does not cover damages resulting from abuse, accidental breakage, or modifications, alterations, or installations that do not comply with the provided installation instructions. The warranty applies only to products that have been properly stored, installed, and maintained in accordance with the installation and operation manual and used for their intended purpose.

This limited warranty does not cover products installed or operated under unusual conditions or environments, including but not limited to excessive humidity or extreme temperatures beyond specified limits.

Prior to returning a product, Growlink must be contacted to obtain a return authorization. Returns will not be accepted without prior authorization. For products not purchased directly from Growlink, proof of purchase is required; otherwise, the purchase date will be considered the date of manufacture.

Products that meet the warranty conditions outlined above will be repaired or replaced at Growlink's sole discretion at no charge. This warranty is provided in place of all other warranties, express or implied, including but not limited to any implied warranties of merchantability or fitness for a particular purpose, and is limited to the specified warranty period.

Under no circumstances shall Growlink be liable to the claimant or any third party for damages exceeding the purchase price of the product. Growlink is not responsible for any loss of use, inconvenience, commercial loss, lost time, lost profits, lost savings, or any other incidental, consequential, or special damages arising from the use or inability to use the product. This disclaimer is made to the fullest extent permitted by law and explicitly states that Growlink's liability under this limited warranty, or any extension thereof, is limited to repairing or replacing the product or refunding the purchase price.