

relayLINK

6-Channel Module

Contents

Specifications 01

Overview 02-03

Warnings and Notices 04 - 05

Installation Instructions 05-07

Device Registration 08-09

Device Connections 10-14

Technical Information 15

Warranty 16



Specifications

Input Power	24VDC - 1.5A Max.
Max Relay Current	1A Per Relay
Max Relay Voltage	24VAC/DC
Minimum Cycle Time	1 Second
Interface	HUB Connection Port
Terminal Wire Gauge	26 - 16 AWG
Tightening Torque	0.3 - 0.4 Nm
Dimensions	4.813"W x 3.5"H x 1.438"D (122mm x 90mm x 36.5mm)

 **KEEP THESE INSTRUCTIONS**

Overview

The relayLINK module connects to a Growlink HUB and provides six (6) individually controllable dry contacts for on/off device control.

relayLINK modules are intended for:

- HVAC Relays (*requires HUB, canopyLINK, Climalink, and lighting control via the 4 channel lightLINK or digital lightLINK for HVAC control*)
- Dehumidifier Control (*applies to units with low-voltage external control options; requires HUB, canopyLINK, and Climalink*)
- Humidifier Control (*applies to units with low-voltage external control options; requires HUB, canopyLINK, and Climalink*)
- Miscellaneous dry contact on/off control

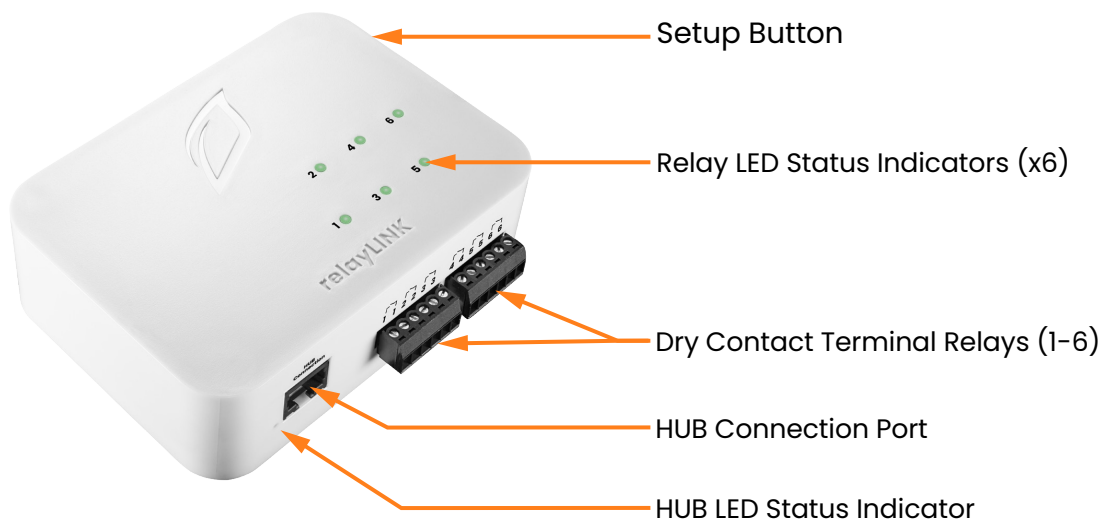

External Features

Setup Button: Readdresses the relayLINK module.

Relay LED Status Indicators (x6): Displays dry contact relay activity.

Dry Contact Terminal Relays (1-6): Terminal connector for dry contact relays.

HUB Connection Port: RJ-45 connector port for power & data.

HUB LED Status Indicator: Indicates device power and HUB communication status.

Relay Outputs

Relay outputs are “dry contact” type. Dry contact relays operate like a wall switch which is simply connecting, or disconnecting, a pair of screw terminals. No voltage is provided from a relay output; external voltage is only passed through the relay from one screw to the other when the dry contact is closed. Dry contacts can switch AC or DC power.

How “Dry-Contact” Relays Work

A relay consists of a mechanical switch and an electro-magnet to turn on (close) a switch contact. A spring opens the switch when the electromagnet is no longer powered. The microprocessor controls the power to the magnet coil to open or close the switch contact as required by the controller program.

Dry-contact relays can be thought of like a wall-switch:

- Each relay “contact” has a pair of screw terminals just like a wall-switch does.
- A wall-switch (or relay contact) does not supply power, it only allows it through.
- Each switch is independent and can operate different circuits or voltages, up to 24 volts.



A dry-contact relay is the same as a wall switch, however, instead of operating the switch manually with your finger, an electromagnet operates the switch.



Warnings and Notices

This is a precision electronic instrument that requires careful handling and maintenance to ensure reliability. Failure to read, understand, and comply with warnings and installation requirements may result in property damage, personal injury, or death.

WARNING

READ & UNDERSTAND THE ENTIRE MANUAL BEFORE INSTALLATION OR OPERATION.

Danger: Electrocutation Hazard

Disconnect power before performing maintenance or service on the system or its components to prevent equipment damage or electrical shock. Ensure proper grounding at the marked chassis ground terminal for continued protection against electric shock. All electrical equipment and wiring must be installed in compliance with national and local electrical codes. This product is for indoor use only in dry locations (0–75% RH, non-condensing). Use caution when servicing plumbing and drain the system away from electrical components and connections. Connect the system and components to GFCI fault-protected energy sources to reduce the risk of electric shock. Replace serviceable parts only with manufacturer-recommended components.

IMPORTANT SAFETY INFORMATION

This Product Is Not Intended for Life Safety Applications

Do not install in hazardous locations. Do not rely on this equipment as the sole control mechanism for life safety applications.

Installation Requirements

Follow all applicable plumbing and electrical codes when installing this product. This manual is intended for individuals with adequate electrical and mechanical experience who comply with federal, state, and local laws governing the installation, service, and repair of electrical, HVAC, and related equipment. Incorrect installation, service, or repair may result in personal injury and/or property damage. The manufacturer and seller assume no liability for misinterpretation or improper use of the information provided.

Indoor Use Only

This product is designed for indoor mounting only and must be protected from weather and direct sunlight.

Prevent Overheating

Maintain adequate airflow around the system to prevent overheating of system components.

Power Supply Warning

Only use the intended or included power supply. Do not exceed the maximum ratings specified on the product's serial label or in this manual. Any power supply exceeding specified energy levels must be current-limited or fused to prevent overcurrent damage.

Dielectric Grease Recommendation

In humid environments, apply dielectric grease to RJ-45 HUB connections to prevent moisture-related corrosion. Recommended products include Loctite LB 8423 Grease, DuPont Molykote 4/5, CRC 05105 Di-Electric Grease, Super Lube 91016 Silicone Dielectric Grease, and other silicone or lithium-based insulating greases. Apply a small amount of grease to RJ-45 plug contacts before inserting them into the HUB connection port.

California Proposition 65 Warning

This product may contain chemicals known to the State of California to cause cancer, birth defects, or other reproductive harm. Wear skin and eye protection when handling hazardous chemicals.

Installation Instructions

Before Installation

For optimal protection, install the unit with the power connection facing downward to minimize the risk of water entering the enclosure. This product is designed for indoor installation only, as the enclosures are not waterproof.

Before connecting or disconnecting any cables, disconnect power from all devices to prevent potential damage to components.

Mounting the Enclosure

For optimal performance and easy service access, mount the relayLINK outside the growing area to reduce exposure to humidity and moisture. If installed in a humid environment, use a sealed or weatherproof enclosure. Mount above plants, benches, and cable runs to prevent water damage to connectors and circuitry. Position centrally to sensor locations with enough space for all connections. Account for rolling benches, and use Growlink cable extensions if needed.

Follow these tips for best results:

- Mount the relayLINK away from drips, condensation, and water equipment such as misters, foggers, and humidifiers.
- Ensure space for connections and service access.
- Use a weatherproof enclosure for high humidity conditions (<70% continuous).
- Cover open jacks with masking tape to prevent dust or contamination.

Wall Mounting

See Instructions and Diagram Below

Parts: LINKS Device, LINK Hardware Kit (Mounting Bracket, Screws, Anchors, Mini-Screwdriver).

Tools Needed (if necessary): Level, Marking Tool, Drill

1. Attach the **Device Mount Bracket (Top)** with the provided screws. Ensure the counter-sunk holes face forward. Do not over-tighten.
2. Position the **Wall Mount Bracket (Bottom)** on the wall. Mark the hole locations and install anchors or pre-drill holes if necessary.
3. Slide the **Device** into place, aligning the **(Top) Device Bracket** with the **(Bottom) Wall Mount Bracket**.

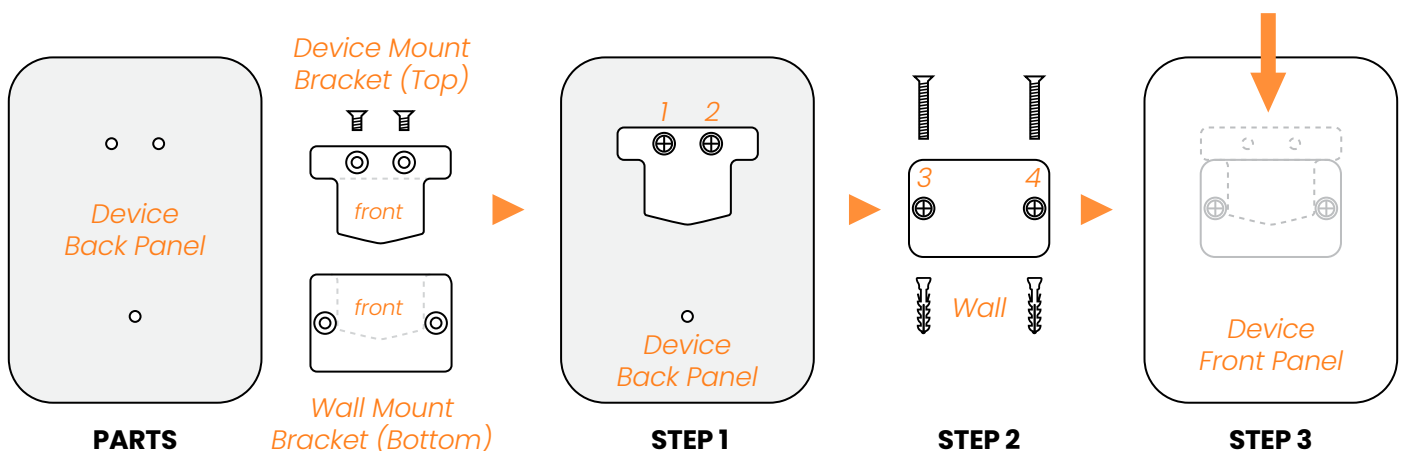

DIN rail Mounting

The DIN rail mounting clips come in handy where standard DIN rail is used for mounting devices. The flat mounting surface and a variety of mounting holes make these clips versatile for mounting LINK devices.

See Instructions and Diagram Below

Parts: LINKS Device, DIN rail Clip Kit, (Sold Separately)

Tools Needed (if necessary): Phillips Screwdriver

1. Position at an Angle

Hold the device at a slight angle with the top part of the DIN rail clip hooking onto the top edge of the rail first. Ensure proper alignment to avoid unnecessary force on the clip.

2. Snap into Place

Gently rotate the bottom of the device toward the rail while applying light pressure. The spring-loaded or flexible lower clip should compress slightly and then snap into place once fully engaged.

3. Verify Secure Fit

Check that the device is firmly seated on the rail by giving it a gentle tug. It should not shift or wobble excessively.

4. Careful Removal: Lift and Pivot

To remove, compress the spring of the mount by gently pressing the device upwards. Once spring is compressed, tilt the top of the device outward at an angle. Then, once top is free, guide device downwards to release from DIN rail completely. Do not force or twist to prevent breaking plastic parts.

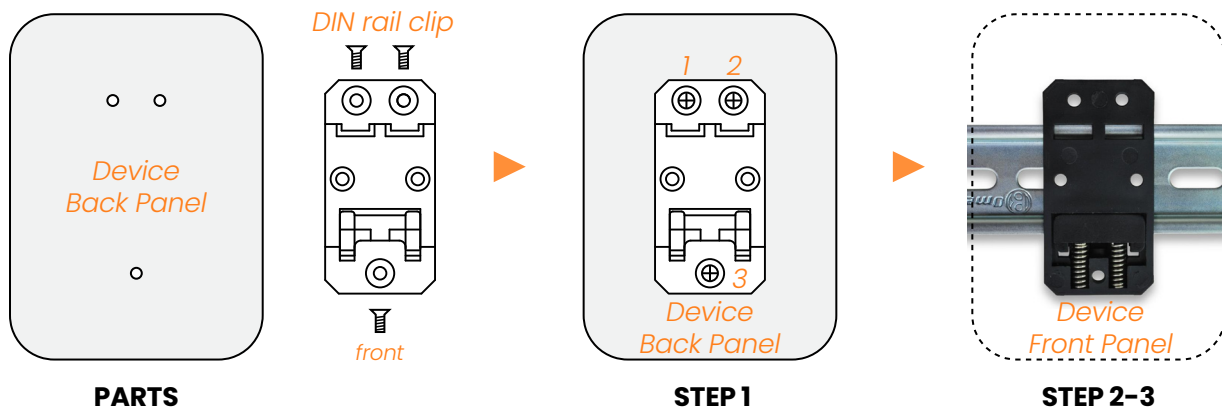

Device Registration

All LINKS devices require an internet connection and must be registered through the Growlink App.

Note: Some LINKS devices can be standalone or require additional modules.

HUB Connection Method

Connect the relayLINK to an available HUB connection port using an unshielded RJ-45 cable. The device draws power through the network cable upon connection. Ensure the RJ-45 cable is secure, then proceed with manual registration.

Note: A HUB must be registered with the Growlink App before connecting any additional devices. After completing the HUB setup, each device must be connected and registered one at a time to ensure proper addressing and system integrity.

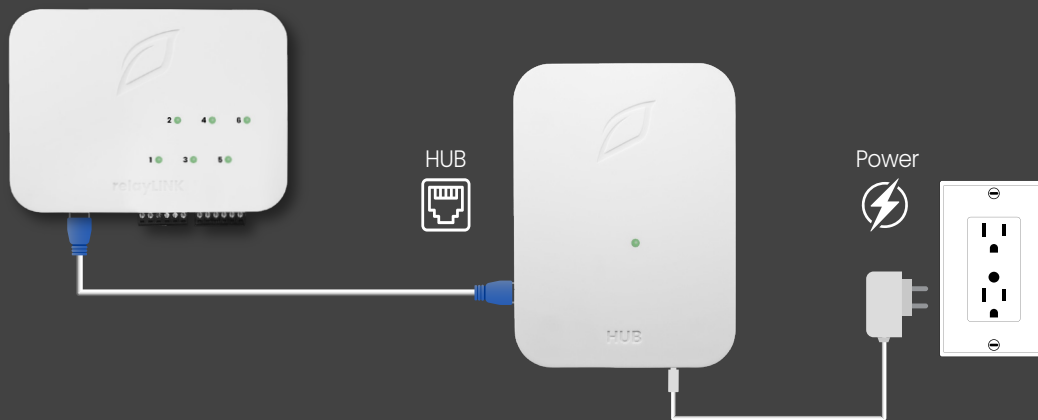

Connection to the Growlink App

The Growlink Mobile App provides remote access to your grow operation, allowing real-time monitoring, system adjustments, and automation of climate, lighting, and irrigation. The app features advanced analytics, push notifications for alerts, and an intuitive interface for efficient management.

The Growlink Mobile App enables remote control over your LINKS devices for:

- Firmware Updates
- Manual Device Operation
- Creating Automation Rules
- Viewing Data
- Sending Alerts
- Various Other Features

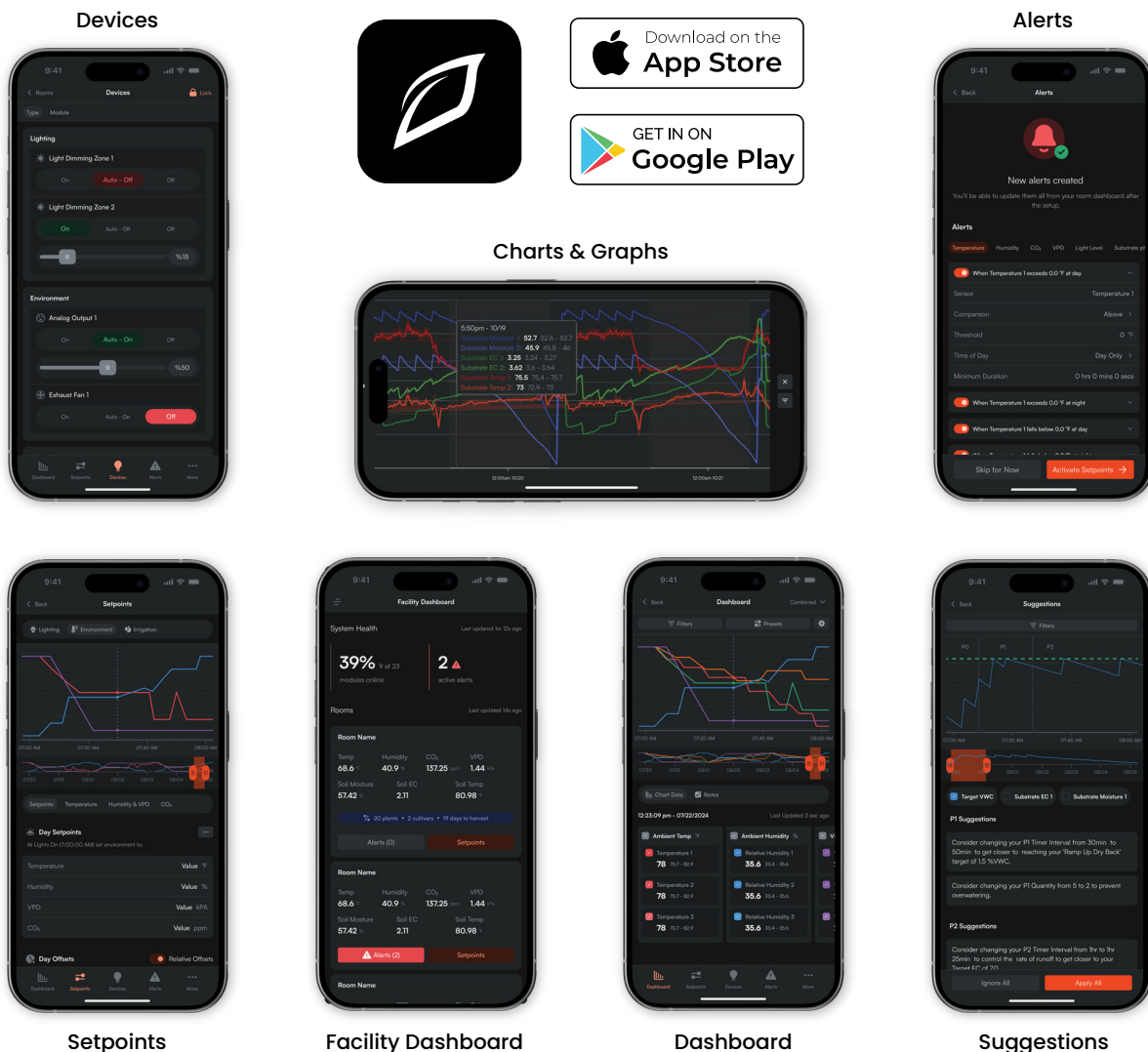

Device Connections

The 6-Channel relayLINK module allows you to manage your grow environment with precision and flexibility. Featuring six (6) 1A dry contact outputs, it enables independent control of HVAC systems, humidifiers, dehumidifiers, and other mixed-voltage equipment—ideal for complex automation setups. Designed for seamless integration, the relayLINK connects easily into your system to automate critical components and maintain optimal growing conditions.

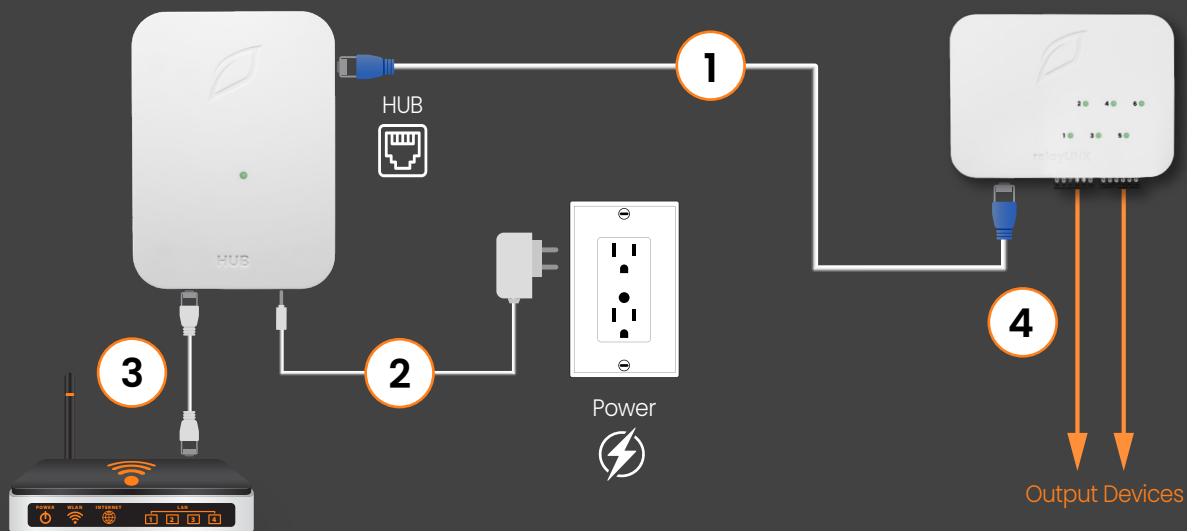

- 1. Device Cable:** Connects the relayLINK to a HUB Connection Port.
- 2. HUB Power Supply:** 24VDC/1 Amp power supply is required to operate the HUB.
- 3. HUB Ethernet Cable:** Connect the HUB to the local network (Optionally, utilize 2.4GHz Wi-Fi).
- 4. relayLINK Terminal Inputs:** (6) 1A dry contact outputs.

All HUB connection cabling uses standard 8-conductor RJ-45 straight-through wiring with no cross-over. T568B pattern recommended.

relayLINK Terminals

relayLINK modules feature six (6) normally open (N.O.) dry contact outputs for operating low-voltage control signals common in HVAC and other control applications. Each contact is capable of 1A at up to 24VAC/DC.

Power is provided to the module via the RJ-45 HUB Connection Port.

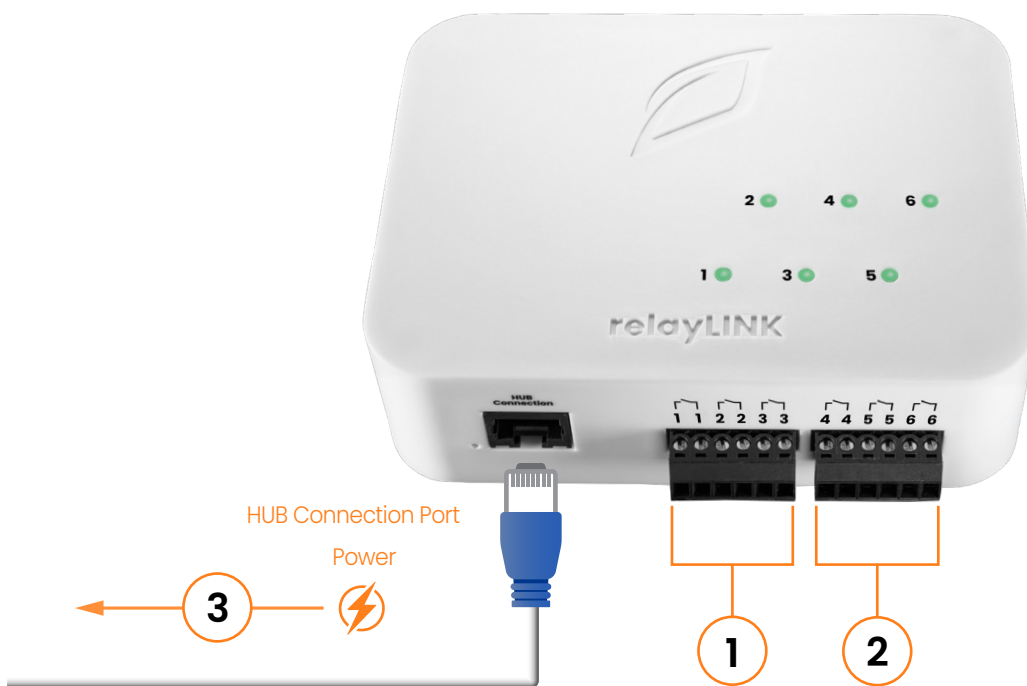

- 1. Terminal Relays (1-3):** Relay contacts 1 through 3, normally open (form A).
- 2. Terminal Relays (4-6):** Relay contacts 4 through 6, normally open (form A).
- 3. HUB Connection Port:** Power is provided to the module via the HUB Connection Port.

relayLINK Outputs (Dry Contacts)

Dry-contact relays consist of a mechanical switch (contact) and an electromagnet that closes the contact when energized. A spring reopens the switch when power is removed. The contact operates similarly to a wall switch, physically connecting two screw terminals. Dry contacts are commonly used to switch low-voltage AC control signals, such as those for HVAC units and irrigation solenoids.

1. Irrigation Solenoid Valves

- 24VAC irrigation and gas valves can be controlled by switching power supplied by a step-down transformer.
- 24VAC is safer and more common than line-voltage for water/irrigation solenoids.

2. A.C. Coil Relays & Contactors

Contactors and relays with 24VAC coils can be operated by controlling the power from a transformer to the magnet coil with a dry contact switch.

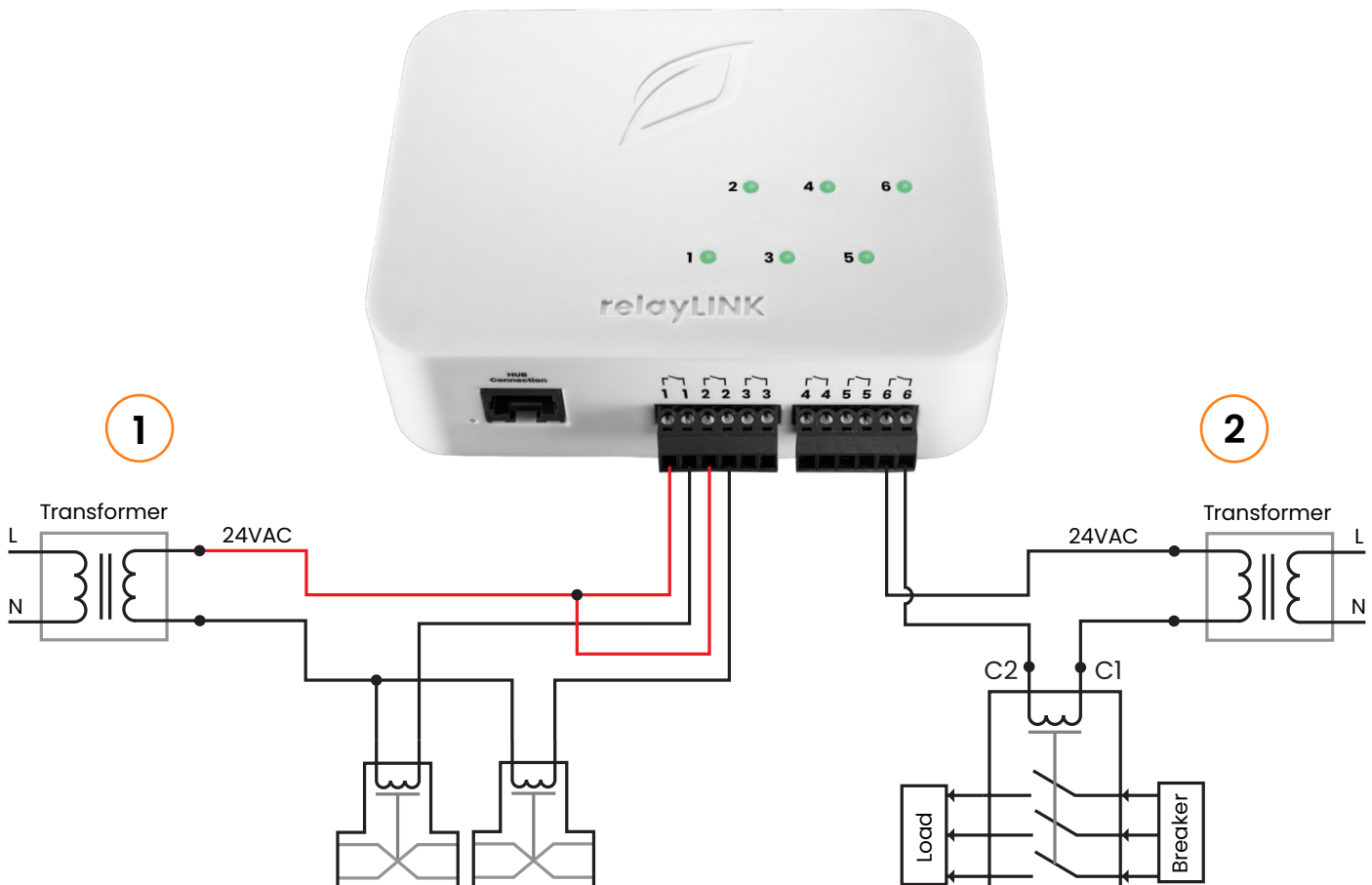

relayLINK Outputs (HVAC Control)

Dry contacts are required to switch the AC control voltage in HVAC and commercial dehumidifier units. HVAC units typically supply 24VAC from a built-in control transformer located in the HVAC unit. The 24VAC supplied by the Unit is switched to the various control signal wires allowing voltage to return to the unit, activating the appropriate component (i.e., Fan, Cooling, Heating, etc.). Do not split the control of a single HVAC unit between multiple relayLINKs (i.e. do not jumper 24V (R) from a single HVAC unit between two different relayLINK devices).

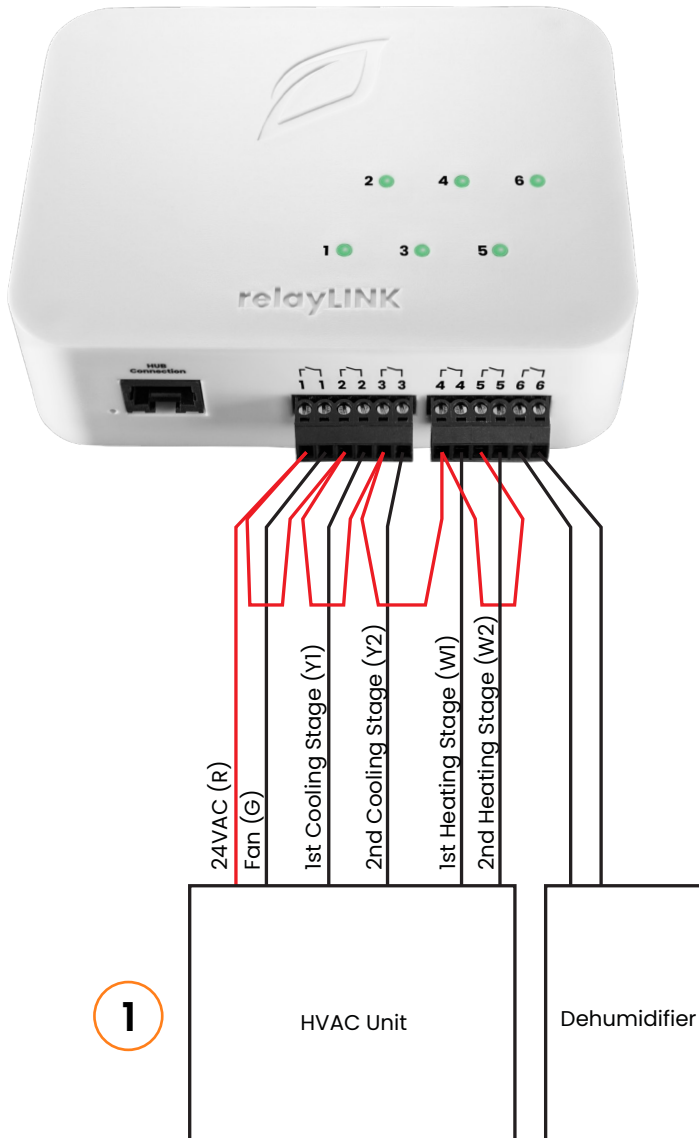

1. HVAC

Typical example of connections to a RTU (roof top unit) HVAC system or other Air Handling Unit or Fan Coil Unit that is controlled with on/off relays.

2. Humidifiers & Dedumidifiers

Commercial humidifiers and dehumidifiers typically provide both an economical internal humidistat control and terminals for external humidistat control. Contact your equipment manufacturer or review your equipment installation manual for details on which connections to make for dry-contact external control.



WARNING: DO NOT split a single HVAC unit's low-voltage control between multiple relayLINKs.

relayLINK Outputs (Anden® Dehumidifiers)

Anden® dehumidifier units can be connected to a low-voltage dry contact for external control. Multiple units can be daisy-chained together as shown in the diagram below.

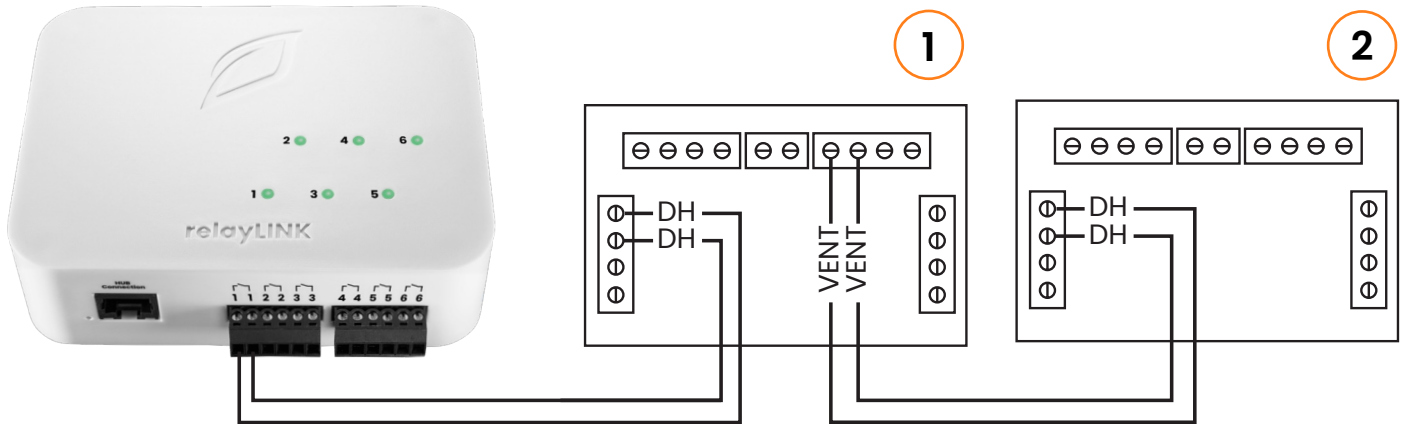

- Connect the “VENT” contacts of Unit #1 to the “DH” contacts of Unit #2.
- Refer to Anden® operation manual for additional setup instructions.

RelayLINK Outputs (Quest® Dehumidifiers)

Quest® dehumidifier units can be connected to a low-voltage dry contact for external control. You may control up to four Quest® units with a dry contact by wiring all Common (COM) terminals and DEHU Terminals together.

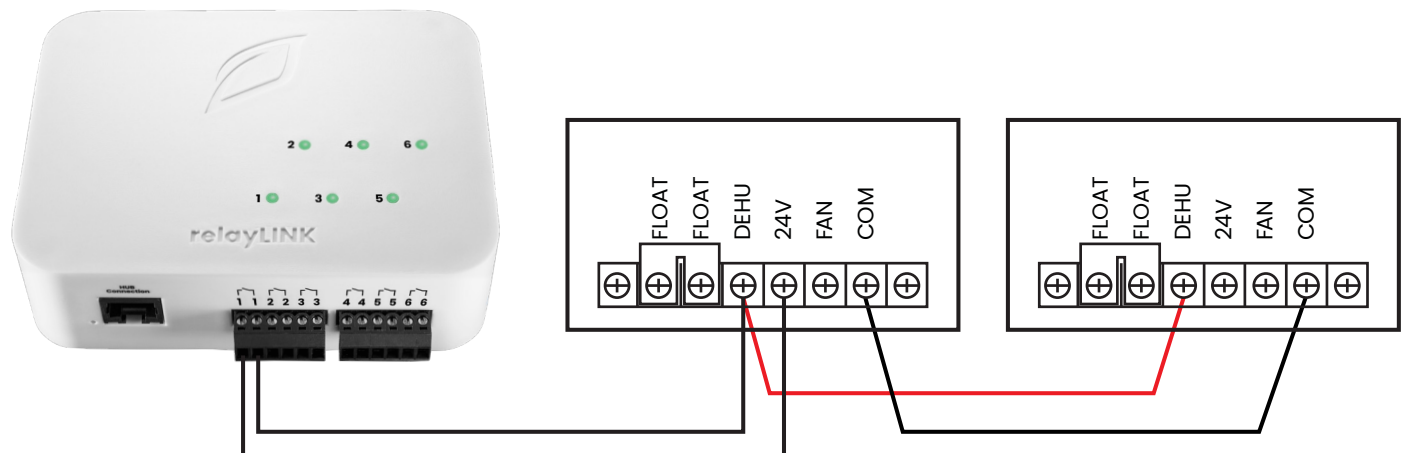

Note: If you don't see a component in the wiring diagram that matches your brand of HVAC system, humidifier, dehumidifier, or other mixed-voltage equipment, contact the manufacturer.

Technical Information

Support

If your device requires troubleshooting beyond what is outlined in this manual, please contact our customer support team at 800.432.0160 or at support@growlink.com for assistance with any hardware issues.

You can also visit our knowledge base for additional support and resources.
<https://knowledgebase.growlink.ag>

Maintenance & Service

Exterior Cleaning

Wipe the exterior with a damp cloth and mild dish detergent, then dry thoroughly. **Disconnect power before cleaning** to prevent equipment damage.

Storage

Store equipment in a **clean, dry environment** with an ambient temperature between 50-122°F (10-50°C).

Disposal

This industrial control equipment may contain traces of lead, metals, or other environmental contaminants. **Do not discard as municipal waste.** Dispose of the equipment through proper recycling or hazardous waste collection channels. **Wash hands after handling internal components or PCBs.**

Warranty

Growlink Limited Warranty

Growlink warrants that all its manufactured products are, to the best of its knowledge, free from defects in materials and workmanship. This product is warranted for one (1) year from the date of purchase. This warranty is extended to the original purchaser from the date of receipt.

This warranty does not cover damages resulting from abuse, accidental breakage, or modifications, alterations, or installations that do not comply with the provided installation instructions. The warranty applies only to products that have been properly stored, installed, and maintained in accordance with the installation and operation manual and used for their intended purpose.

This limited warranty does not cover products installed or operated under unusual conditions or environments, including but not limited to excessive humidity or extreme temperatures beyond specified limits.

Prior to returning a product, Growlink must be contacted to obtain a return authorization. Returns will not be accepted without prior authorization. For products not purchased directly from Growlink, proof of purchase is required; otherwise, the purchase date will be considered the date of manufacture.

Products that meet the warranty conditions outlined above will be repaired or replaced at Growlink's sole discretion at no charge. This warranty is provided in place of all other warranties, express or implied, including but not limited to any implied warranties of merchantability or fitness for a particular purpose, and is limited to the specified warranty period.

Under no circumstances shall Growlink be liable to the claimant or any third party for damages exceeding the purchase price of the product. Growlink is not responsible for any loss of use, inconvenience, commercial loss, lost time, lost profits, lost savings, or any other incidental, consequential, or special damages arising from the use or inability to use the product. This disclaimer is made to the fullest extent permitted by law and explicitly states that Growlink's liability under this limited warranty, or any extension thereof, is limited to repairing or replacing the product or refunding the purchase price.